



WWW.ELICHENS.COM

Datasheet – Cranberry_CO2, Ultra-Low power, 1-Series Sensor, CRA-30-243

Revision	Date	Description of Change
1.0	03/2019	Initial version
1.1	07/2020	Update and new graphic charter
1.2	12/2020	Confidentiality removed
1.3	03/2021	Update



1. Key features

- New 1-series ultra-compact formfactor
- 0 – 50,000 ppm measurement range
- No False alarms due to environmental transients
- Fail Safe
- Fast response time, $T_{90} < 30s$
- Ultra-low power consumption: $< 2mW$
- Very low peak current: $< 4mA$
- Simple digital communication UART interface
- 10+ year lifetime
- High accuracy
- Temperature compensated
- Zone 0, ATEX & IECEx certified

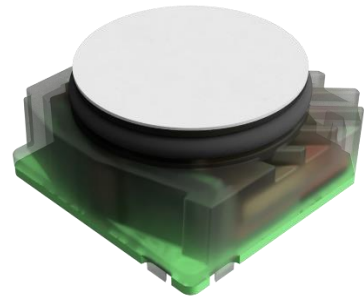

2. Applications

- Performance certified industrial/commercial health and safety devices
- Wireless fixed monitors, > 10 -year battery life
- Portable & wearable devices, > 2 -year battery life

3. Description

Cranberry sensors are cutting-edge NDIR (Non-dispersive Infrared), dual-channel, gas sensors integrated in the new 1-series form factor. They are based on eLichens' patented technology including a proprietary IR micro-source, patented optical design and advanced signal processing algorithms. It provides Cranberry sensors the lowest power consumption and the highest stability on the market in a compact formfactor. These are key differentiators allowing the development of innovative battery-powered safety products.



4. Specifications

Functional specifications @ 25°C, 50%RH			
Technology	Non-Dispersive Infrared (NDIR), Dual-channel		
Gas sampling method	Diffusion		
Target gas	CO2		
Measurement range	0...50 000ppm		
Data rate	2 measurements / second		
Accuracy	±500ppm or ±10% of concentration (whichever is greater)		
Resolution	100 ppm		
Warm up time	30 seconds		
Response time T₉₀	30 seconds		
Expected Lifetime	>10 years		
Electrical specifications			
Supply voltage	2.9...5.0 V		
Average power consumption	< 2.0 mW @3.3V		
Average current consumption	< 610 µA		
Peak current	< 4.0 mA		
Output	Digital, UART		
Rx/Tx/CS voltage levels			
Pin#	Min	Typical	Max
Supply	2.9 V	3.3 V	5.0 V
Rx (V_{IL})	-0.3 V	-	0.8 V
Rx (V_{HL})	2.0 V	-	4.0 V
Tx (V_{OL})	0	-	0.4 V
Tx (V_{OH})	2.3 V	2.8 V	2.9 V
CS	0	-	4.0 V



Environmental specifications				
Operating temperature range	-20...60°C			
Operating humidity range	0...99%RH, non-condensing			
Storage temperature range	-40...80°C			
Qualification information				
Description	Conditions	Min	Typ.	Max
Lifetime	For a period of 8h per working day	5 y	10 y	
EMC (Electromagnetic Compatibility)	Comply with standards: EN 61000-6-4 & EN 50270			
ESD (Electrostatic Discharge)	Human body model (HBM), per ANSI/ESDA/JEDEC JS-001 ⁽¹⁾		±2000 V	
	Charged device model (CDM), per JEDEC specification JESD22-C101 ⁽²⁾		±500 V	

⁽¹⁾ JEDEC standard JEP155 states that 2kV HBM allows safe manufacturing with a standard ESD control process.

⁽²⁾ JEDEC standard JEP157 states that 500V CDM allows safe manufacturing with a standard ESD control process.



5. Outline

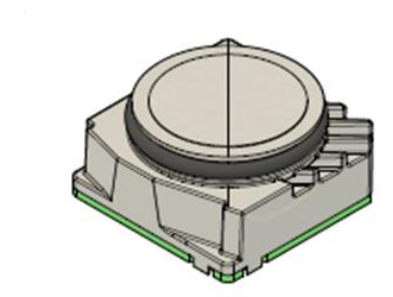
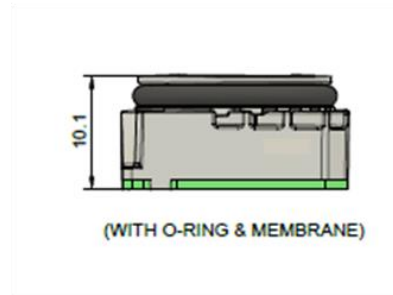
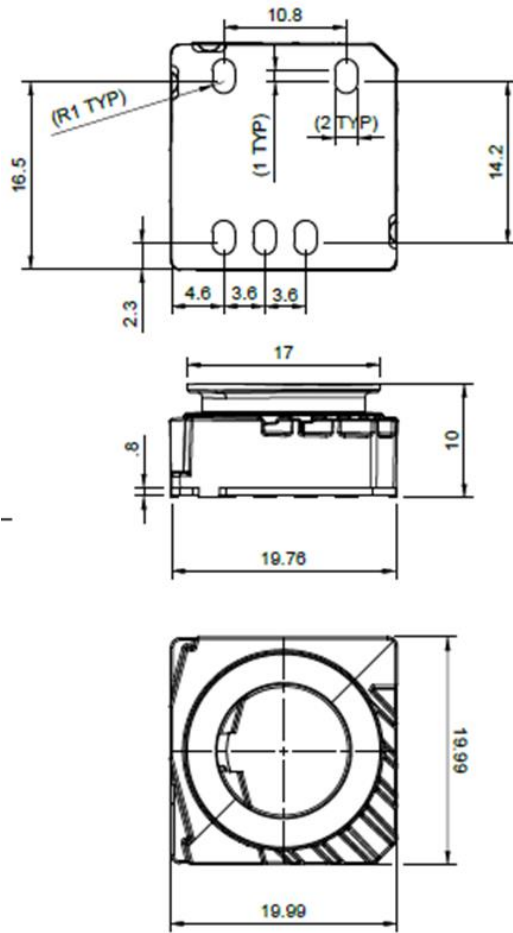

All dimensions are in millimeters [mm]

6. Pinout

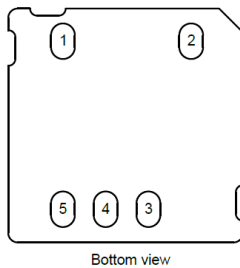

Pin#	Name	Type	Description
1	VCC	Power	Power supply
2	GND	Power	Power Ground
3	Tx	Output	Asynchronous transmit to Host Controller UART
4	Rx	Input	Asynchronous receive from Host Controller UART
5	CS	Input	Chip Select (active 'low'), a falling edge on this pin wake up the sensor and activate the communication port. A rising edge deactivate the communication port of the sensor.



7. Intrinsic safety

Cranberry sensors are safe to use in explosive atmosphere because they are intrinsically safe regarding the ATEX and IECEx certification. It has been certified by the certification agency Ineris (code 0080).

Cranberry sensors are certified for intrinsic safety including the following certifications:

- IEC/EN 60079-0: 2012 + A11: 2013
- IEC/EN 60079-11: 2013
- IEC/EN 60079-28: 2015
- EN 50303: 2000

ATEX certificate:

Certificate number: INERIS 19ATEX9001U

Cranberry sensors respect the two following markings:

- Ex ia op is IIC Ga
- Ex ia op is I Ma

The marking on the sensor will be:



Cranberry sensors can be used in explosive gas atmosphere and in Mines susceptible to firedamp. For both areas, the sensors are safe to be used in Zone 0, atmosphere area having a permanent and/or prolonged risk of explosions.

Equipment category and Equipment protection level (EPL)

The sensor is intrinsically safe if the implementation of the sensor complies with the following rules:

- Electrical parameters (U_i , I_i , P_i , C_i , L_i) are limiting to intrinsic values according to the standard EN 60079-11.
- Cranberry sensor is compliant with the ATEX temperature class T4 for a maximal ambient temperature of +60°C.

Intrinsic input parameters:

- $U_i = 5.0V$
- $I_i = 1.2A$
- $P_i = 1.2W$
- $C_i = 39\mu F$
- $L_i = 0\mu H$



8. Packaging and Order Information

8.1. Packaging

Note: Information subject to change

The sensor is packaged inside a plastic tray as shown in the pictures below.

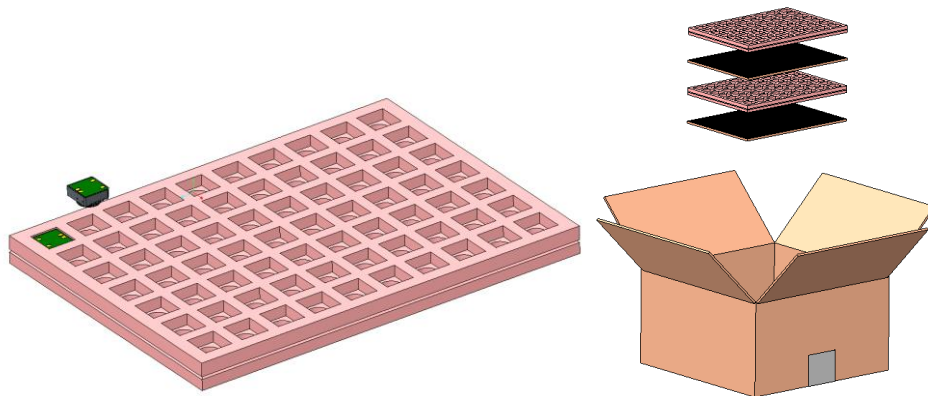

8.2. Part number

Cranberry CO₂ sensors can be ordered via the following article numbers.

Target gas	Full scale	Temperature range	APP CODE	Part number
CO ₂	0 – 50000 ppm	-20 to 60°C	243	CRA-30-243



For further information, please contact:

eLichens
17 rue Félix Esclançon
38000 Grenoble
FRANCE

info@elichens.com
www.elichens.com